

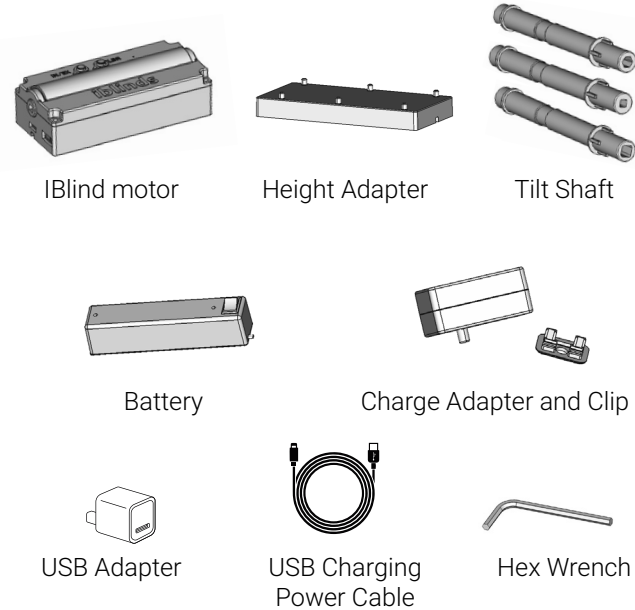

## QUICK START GUIDE

For detailed installation instructions and installation video guides visit our website [support.myiblinds.com](http://support.myiblinds.com).

### IBLINDS KIT CHECK LIST



### IBLIND MOTOR

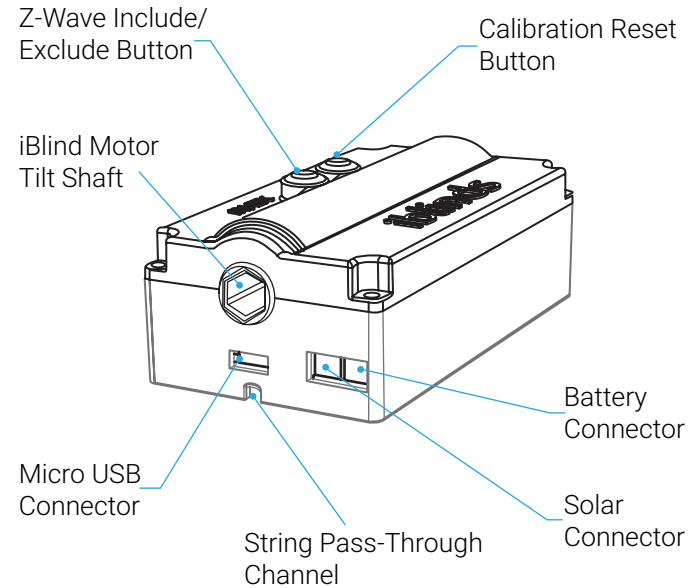

### WINDOW BLIND COMPONENTS

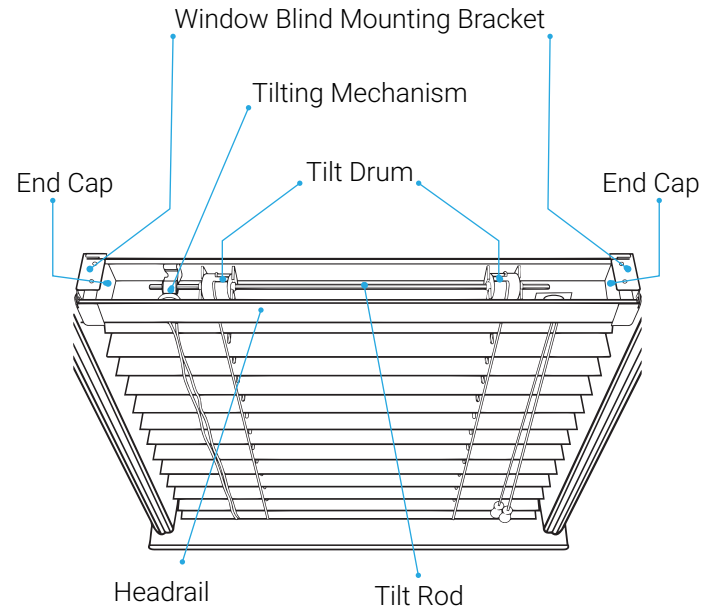

### INSTALLATION

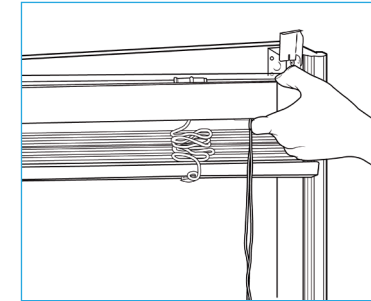

Step 1  
Remove existing blind.

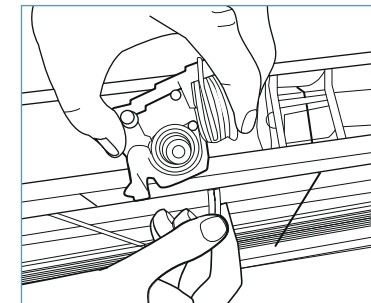

Step 2  
Remove existing tilt mechanism.

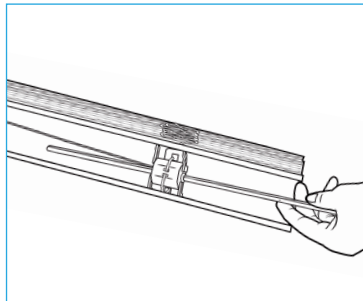

**Step 3**  
Remove tilt rod from headrail.

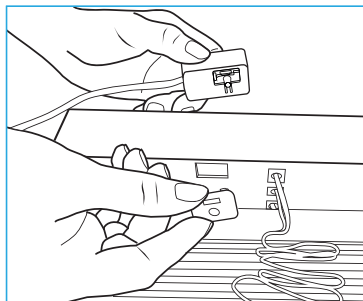

**Step 4**  
Install charge adapter inside headrail and attach clip from the bottom. Wires should be facing outer end of blind, with micro USB port facing front.

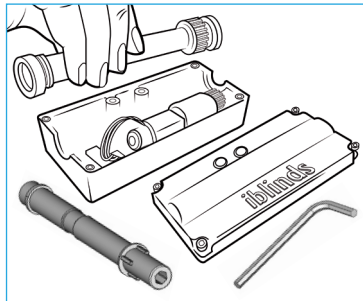

**Step 5**  
Select tilt shaft to match tilt rod size & shape. Remove lid using included hex wrench & install appropriate tilt shaft. Replace lid.

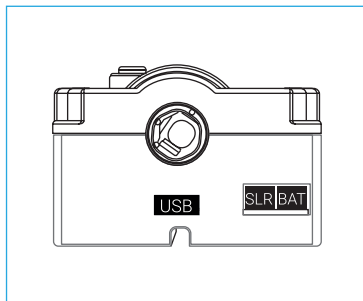

**Step 6**  
Connect battery cable to the orange BAT port. Connect Charge adapter cable to the USB port.

*For more power options visit our support website - [support.myiblinds.com](http://support.myiblinds.com)*

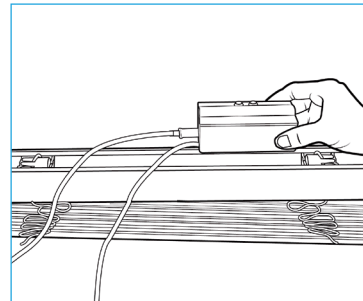

**Step 7**  
Install iBlind motor in blind head rail with buttons at the back. Make sure tilt shaft is aligned with tilt rod holes in tilt drums. If needed, use included height adapter.

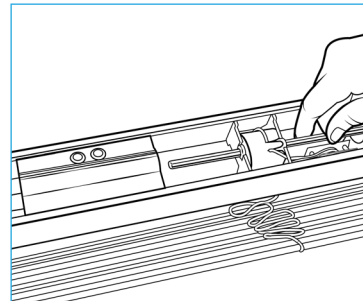

**Step 8**  
Re-insert tilt rod, rotating it to pass through the shaft. Be careful to keep all tilt drums in the same orientation.

**Step 9**  
Carefully tuck the cables into the headrail. Take care to route the hidden cables where they won't interfere with the tilt rod or any of the other moving mechanisms in the headrail.

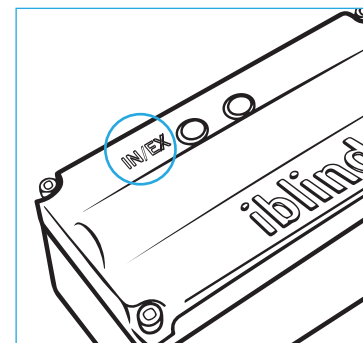

**Step 8**  
Follow your Z-Wave controller's directions to place it in inclusion mode. Make sure iBlind device is powered on. Press the inclusion button once and wait for the device to be discovered and joined to the Z-Wave network.

## CHARGING

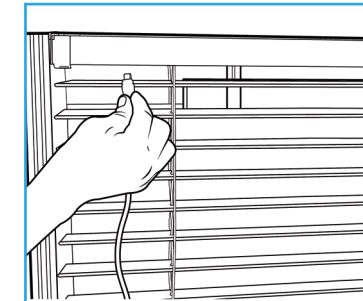

Use the USB Cable and Power Adapter to charge battery approx. every 5-6 months.

*For more charging options visit our support website [support.myiblinds.com](http://support.myiblinds.com)*